

Description Heavy Duty Structural Rivet Hand Tool 3/16" & 1/4"

This tool installs 3/16" & 1/4" Structural Rivets. The long arms provide the leverage required to set structural rivets quickly and easily.



Specifications

Model	K35F
Type	Long Arm Type
Construction	Pressed Metal Frame
Capacity	3/16" & 1/4" Structural Rivets
Weight	2.4Kg

Dimensions

A	24 mm
B	90 mm
C	600 mm

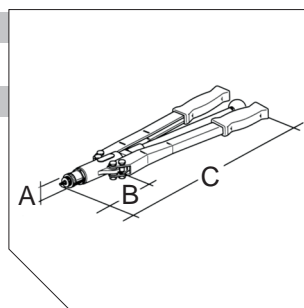

Dimensions and specifications are subject to change without notice. Check your distributor for the latest data sheet.

Brisbane: 3/97 Delta Street
Geebung Q 4034
Ph: (07) 3265 2267
Fax: (07) 3265 2257
Email: sales@profast.com.au
Web: www.profast.com.au

Perth: 7/126 Bannister Rd
Canning Vale WA 6155
Ph: (08) 9456 5537
Fax: (08) 9455 2659
Email: saleswa@profast.com.au
Web: www.profast.com.au